

## Model N23343 Markus® Plane-Parallel Ion Chamber

The Model N23343 Markus® plane-parallel ionization chamber is designed specifically for the dosimetry of electrons with energies above 100 keV, according to the Bragg-Gray principle. It is suitable for measurements in either solid or water phantoms.

The chamber consists of a cylindrical acrylic body whose measuring volume is flush to the surface to permit dose measurements at very small depths. The entrance window is made of polyethylene (2.5 mg/cm<sup>2</sup>) with a graphite conductive coating. The ion collector is graphite coated acrylic and is provided with a guard ring that rests at ground potential. The low collector volume minimizes polarity effects and electrostatic charge. The chamber is vented to the atmosphere and equilibrates through the aperture in the window ring. The design provides for energy independence, high spatial resolution, and minimizes polarity and perturbation effects.

The Model N23343 includes a 0.87 mm thick acrylic protective cap for use in a water phantom, a spacer ring for use in a solid phantom and an acrylic buildup disc. For measurements in water phantoms, equilibration may be achieved by taking the protective cap off briefly just before the measurement is taken.

dimensions in mm

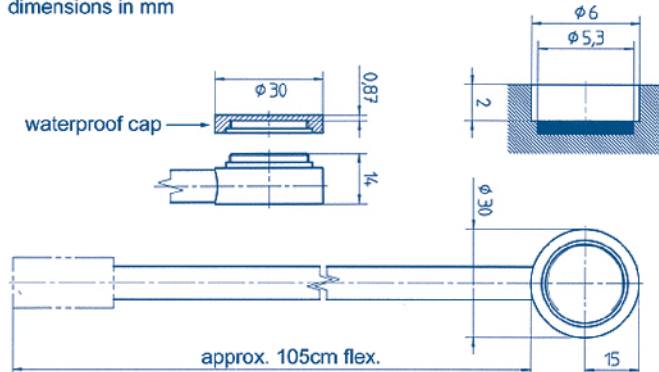

### Features:

- ▶ Waterproof
- ▶ 5.3 mm diameter collector
- ▶ Characterized for TG-51

### Specifications

$N_{\text{gas}}/(N \times A^{\text{ion}})$ (cGy/R):	..... 0.859
Kecal :	..... 0.905
Volume:	..... 5.5 cc, nominal, vented to the atmosphere
Sensitivity:	..... 0.018 nC/cGy, nominal
Leakage current:	..... $< 2 \times 10^{-16}$ A
Body Material:	..... acrylic
Entrance window:	..... 0.03 mm polyethylene, 2.5 mg/cm <sup>2</sup>
Ion collector:	..... 5.3 mm diameter, acrylic, graphite coated
Electrode separation:	..... 2 mm
Guard ring:	..... 0.1 mm wide
Bias voltage:	..... $\pm 400$ V maximum
External dimensions:	..... 30 mm diameter x 14 mm
Protective cap:	..... acrylic, 0.87 mm thick, 102.6 mg/cm <sup>2</sup>
Build-up cap:	..... acrylic, 30 mm diameter, 3.18 mm thick, 376 mg/cm <sup>2</sup>
Cable:	..... 1 meter, low-noise triaxial, BNC male triaxial (TNC optional)

### Accessories

CH-1	..... Cradle-type holder with 7 mm diameter stem for Markus®, PPC05, A10 and NACP chambers
3BM-F10	..... 10 m extension cable, triax BNC, male/female with caps and chains (also available in custom lengths and/or mounted in a reel)
3BF-3TMF	..... Triaxial BNC to TNC adapter

\* Designed by Prof. B. Markus, University of Göttingen, Germany. Markus® is a registered trademark of PTW Freiburg & PTW New York.