



Specifications

Model:	A1SL	A14SL	A16
Volume:	0.056 cc	0.009 cc	0.007 cc
Sensitivity:	0.018 nC/cGy	0.003 nC/cGy	0.0023 nC/cGy
Thimble o.d.:	6.25 mm	6.25 mm	3.4 mm
Wall thickness:	1.1 mm	1.1 mm	0.5 mm
Collector diameter:	1.0 mm	0.3 mm	0.3 mm
Collector length:	4.4 mm	1.5 mm	1.3 mm
Reference point:	4.1 mm	2.0 mm	1.7 mm
Wall material:	C552 Shonka air-equivalent conductive plastic		
Collector material:	C552		
Leakage:	<1 fA		
Bias:	±300 V typical, 1000 V maximum		
Venting:	through sheathed cable		
Stem:	aluminum, integral with chamber, 6.35 mm diameter, 10.16 cm long (other length stems available)		
Cable:	triaxial, 3 meters long		
Connector:	triaxial BNC (TNC optional)		

Accessories

72125	⁶⁰ Co buildup cap for A1SL, A14SL 3BM-F10 10 m extension cable, triax BNC, male/female with caps and chains (also available in custom lengths and/or mounted in a reel)
3BF-3TMF	Triaxial BNC to TNC adaptor

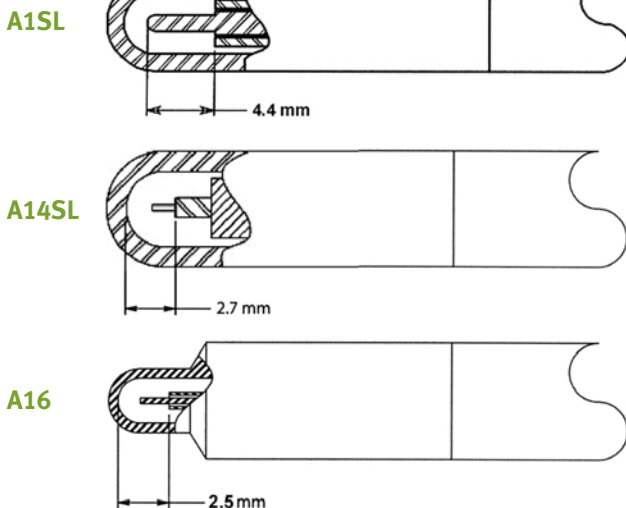

Slim-Line Miniature Thimble Chambers

Model A1SL: 0.056 cc

Model A14SL: 0.009 cc

Model A16: 0.007 cc

Slim-Line miniature chambers were developed specifically for assessment of the radiation fields encountered in stereotactic surgery where an extremely small sensing volume is needed to achieve good spatial resolution. Slim-Line design provides compact profile, but does not allow for gas circulation through the sensing volume.

Internally, A1SL is identical to the A1 and Model A14SL is identical to Model A14. Externally, the A1SL and the A14SL differ in having a uniform thimble and stem diameter of only 6.25 mm.

To insure atmospheric equilibrium, the chambers are vented through the sheathed cable and are therefore inherently waterproof.

The chamber wall, collector and guard are made entirely of C552 conducting Shonka plastic, a highly homogenous air-equivalent formulation which makes it ideally suited to the measurement of exposure. C552 consists of polyvinylidene fluoride matrix, in which finely divided inert powders of carbon black and silica are uniformly dispersed. Density is 1.76 g/cm³. Electrical resistivity is on the order of 0.03 ohm-meter. Carbon black is the main source of electrical conductivity.

